



FÉDÉRATION INTERNATIONALE DE MOTOCYCLISME

Technical Rules

General Section

Motocross

(Including Rules for Quads and Snowcross)

Trial

Enduro

(Including Rules for Cross-Country Rallies)

Track Racing

(Including Rules for Motoball)

2009

Règlements Techniques

Section générale

Motocross

(Règlements pour Quads et Motoneige inclus)

Trial

Enduro

(Règlements pour Rallyes Tout Terrain inclus)

Courses sur Pistes

(Règlements pour Motoball inclus)

Technical Rules General Section

Règlements Techniques Section générale

These articles, from 01.01 until 01.81 apply to all the disciplines hereafter.
Ces articles, de 01.01 à 01.81 s'appliquent à toutes disciplines ci-après.

TECHNICAL RULES – GENERAL SECTION

TABLE OF CONTENTS

01.01	INTRODUCTION	2
01.03	FREEDOM OF CONSTRUCTION	2
01.05	CATEGORIES AND GROUPS OF MOTORCYCLES	2
01.07	CLASSES	3
01.11	MEASUREMENT OF CAPACITY	4
01.17	SUPERCHARGING	5
01.18	TELEMETRY.....	5
01.19	MOTORCYCLE WEIGHTS.....	5
01.21	DESIGNATION OF MAKE	6
01.23	DEFINITION OF A PROTOTYPE	6
01.25	GENERAL SPECIFICATIONS	6
01.26	DEFINITION OF A FRAME OF A SOLO MOTORCYCLE	8
01.27	STARTING DEVICES	8
01.29	OPEN TRANSMISSION GUARDS	8
01.31	EXHAUST PIPES	8
01.33	HANDLEBARS	9
01.35	CONTROL LEVERS	10
01.37	THROTTLE CONTROLS	10
01.39	FOOTRESTS	10
01.41	BRAKES	11
01.43	MUDGUARDS AND WHEEL PROTECTION	11
01.45	STREAMLINING	11
01.47	WHEELS, RIMS, TYRES	12
01.49	MOTOCROSS TYRES	12
01.53	ADDITIONAL SPECIFICATIONS FOR SIDECARS	12
01.55	NUMBER PLATES	14
01.63	FUEL, FUEL/OIL MIXTURES	15
01.65	EQUIPMENT AND PROTECTIVE CLOTHING	21
01.67	WEARING OF HELMETS	21
01.69	HELMET OPERATIVE INSTRUCTIONS	22
01.70	RECOGNISED INTERNATIONAL APPROVAL MARKS	23
01.71	EYE PROTECTION	23
01.73	NATIONAL COLOURS FOR HELMETS	24
01.75	BADGE OF THE FIM	25
01.76	NUMBER SASHES (BIBS)	25
01.77	CONTROL	25
01.79	SOUND CONTROL	26
01.80	GUIDELINES FOR USE OF SOUND LEVEL METERS	29
01.81	TIME KEEPING	30
DIAGRAMS.....	31

01.01 INTRODUCTION

The term motorcycle covers all vehicles having, in principle, less than four wheels, propelled by an engine and designed essentially for the carriage of one or more persons of which one is the rider of the vehicle. The wheels must normally be in contact with the ground except momentarily or in certain exceptional circumstances. Furthermore, in order to traverse certain surfaces one or all of the wheels can be replaced with skis, rollers or chains.

01.03 FREEDOM OF CONSTRUCTION

A motorcycle must conform to the requirements of the FIM regulations, to the Supplementary Regulations, as well as to a number of specific conditions that the FIM may require for certain competitions. No restriction is placed on the make, construction or type of motorcycle used.

All solo motorcycles (Group A) must be constructed in such a way that they are entirely controlled by a rider. Motorcycles with Sidecars (Group B) must be constructed to carry a passenger.

01.05 CATEGORIES AND GROUPS OF MOTORCYCLES

Motorcycles are divided into categories which must be observed for all meetings and world record attempts.

In principle, it is forbidden for different categories, groups and classes to compete in the same race, unless the Supplementary Regulations state otherwise.

Category I

Motorcycles propelled by the action of one wheel in contact with the ground.

Category II (not applicable for Track Racing)

Special vehicles propelled by the action of one or more wheels in contact with the ground but which are not covered by the conditions of Category I.

Group A1 – Solo Motorcycles

2-wheel vehicles making only one track on the ground.

Group B1

Vehicles with three wheels, making two tracks on the ground, consisting of a motorcycle making one track and a Sidecar for a passenger making the other.

Group B2

Vehicles with three wheels, making two or three tracks on the ground in the direction of forward travel, with a permanently attached Sidecar forming a complete integral unit.

If three tracks are made, the centre-line of the two tracks made by the motorcycle wheels must not be more than 75 mm apart. A track is determined by the longitudinal centre-line of each of the vehicle's wheels in the direction of forward travel.

Category II (not applicable for Track Racing)

- Group C – Special 2 wheel driven motorcycles
- Group D – Special 3 wheel, 2 wheel driven motorcycles
- Group E – Snowmobiles
- Group F – Sprinters and Dragsters
- Group G – Quad Racers
- Group H –
- Group I –

Category III (not applicable for Track Racing)

- Group J – Electric Vehicles (see Article 01.82 in the Road Racing Technical Rules)

01.07 CLASSES

Groups are again separated into classes according to cylinder capacities as detailed below. Generally, these classes must be observed for all meetings.

For specific details, refer to this article of each discipline (CMS, CTR, CER, CCP).

01.11 MEASUREMENT OF CAPACITY

11.11 Reciprocating movement engine, "Otto" Cycle

The capacity of each engine cylinder is calculated by the geometric formula which gives the volume of a cylinder; the diameter is represented by the bore, and the height by the space swept by the piston from its highest to lowest point:

$$\text{Capacity} = \frac{D^2 \times 3.1416 \times C}{4}$$

where D = bore
and C = stroke

When a cylinder bore is not circular the cross sectional area must be determined by a suitable geometrical method or calculation, then multiplied by the stroke to determine capacity.

When measuring, a tolerance of 1/10 mm is permitted in the bore. If with this tolerance the capacity limit is exceeded for the class in question, a further measurement should be taken with the engine cold, to 1/100 mm limits.

11.13 Rotary engines

The capacity of an engine which determines the class in which the motorcycle shall compete in a meeting shall be calculated by:

$$\text{Capacity} = \frac{2 \times V}{N}$$

where V = total capacity of all the chambers comprising the engine
and N = number of turns of the motor necessary to complete one cycle in a chamber.

Classified as a 4-stroke.

11.15 Wankel system

For Wankel system engines with a triangular piston, the capacity is given by the formula:

$$\text{Capacity} = 2 \times V \times D$$

where V = capacity of a single chamber
and D = number of rotors.

This engine is classified as a 4-stroke.

01.17 SUPERCHARGING

Supercharging by means of a device of any kind is forbidden in all meetings.

An engine whether 2-stroke or 4-stroke coming within any one of the recognised classes (determined by the capacity of the working cylinder) shall not be considered as supercharged when in respect of one engine cycle, the total capacity measured geometrically, of the fuel charging device or devices, including the capacity of the working cylinder (if used for injecting the fuel), does not exceed the maximum capacity of the class in question.

01.18 TELEMETRY

Information must not be transmitted in any way to or from a moving motorcycle. An official signalling device may be required on the machine. Automatic lap timing devices are not considered as "telemetry". Automatic lap timing devices must not disrupt any official time keeping methods and equipment.

01.19 MOTORCYCLE WEIGHTS Weights of motorcycles without fuel

19.01

For specific details, refer to this article of each discipline (CMS, CTR, CER, CCP).

A 1 % tolerance in the weight of the machine after the race is accepted.

19.03

Seals must be fixed to the front main frame.

19.04

Weighing scales must be certified annually by a National Institute.

19.05

For Groups B1 and B2 at all competitions a passenger must be carried.

01.21 DESIGNATION OF MAKE

When two manufacturers are involved in the construction of a motorcycle the name of both must appear on the machine as follows:

- The name of the chassis manufacturer
- The name of the engine manufacturer

This applies where no commercial interests are involved.

01.23 DEFINITION OF A PROTOTYPE

A prototype motorcycle is a vehicle which must conform to the safety requirements as required by the FIM Sporting Code and Appendices applicable to the type of competition for which it is to be used.

01.25 GENERAL SPECIFICATIONS

The following specifications apply to all vehicles of the groups indicated and to all types of competitions except where otherwise stated in the corresponding section of the FIM Sporting Code.

They should also be applied to all national competitions unless the FMNR (National Motorcycling Federation) has otherwise directed.

Further specifications for some competitions may also be required and these will be detailed in either the appropriate FIM Appendix or in the Supplementary Regulations for the competition in question.

25.01

The use of titanium in the construction of the frame, the front forks, the handlebars, the swinging arms, the swinging arm spindles and the wheel spindles is forbidden.

The use of light alloys for wheel spindles is also forbidden (except for Trial motorcycles).

The use of titanium alloy nuts and bolts is allowed.

Titanium test to be performed at trackside:

25.01.1 Magnetic test (titanium is not magnetic).

25.01.2 3% nitric acid test (Titanium does not react. If metal is steel, the drop will leave a black spot).

25.01.3 Specific mass of titanium alloys 4,5-5, of steel 7,5-8,7 can be ascertained by weighing the part and measuring its volume in a calibrated glass vessel filled by water (intake valve, rocker, connecting rod, etc.)

25.01.4 In case of doubt, the test should take place at a Materials Testing Laboratory.

25.02

Aluminium alloys can be ascertained visually.

25.06

The number of cylinders in an engine is determined by the number of combustion chambers.

25.07

If separate combustion spaces are used they must be connected by an unrestricted passage of minimum cross sectional area at least 50 % of the total inlet port area.

01.26 DEFINITION OF A FRAME OF A SOLO MOTORCYCLE

The structure or structures used to join any steering mechanism at the front of the machine to the engine/gear box unit and to all components of the rear suspension.

01.27 STARTING DEVICES

For specific details, refer to this article of each discipline (CMS, CTR, CER, CCP).

01.29 OPEN TRANSMISSION GUARDS

For specific details, refer to this article of each discipline (CMS, CER, CTR, CCP).

01.31 EXHAUST PIPES

Exhaust pipes and silencers must fulfill all the requirements concerning sound control (see also Art. 01.79).

31.01

The end of the silencer must be horizontal and parallel (over a minimum distance of 30 mm) to the central axis of the solo motorcycle (with a tolerance of $\pm 10^\circ$) and must not exceed the end of the silencer body by more than 5 mm. All sharp edges must be rounded with a minimum radius of 2 mm (See diagram E).

31.02

Exhaust fumes must be discharged towards the rear but not in a manner as to raise dust, foul the tyres or brakes, or inconvenience a passenger, if there is one, or any other riders.

All possible measures must be taken to prevent the possible loss of waste oil so that it does not inconvenience a following rider.

31.03

The extremity of the exhaust pipes on solo motorcycles must not pass the vertical tangent of the rear tyre.

31.04

On a Sidecar machine the exhaust must discharge horizontally and towards the rear, at a maximum angle of 30° to the axis of the machine.

01.33 HANDLEBARS**33.01**

The width of handlebars (solo and Sidecars) is: not less than 600 mm and not more than 850 mm.

33.02

The handlebars must be equipped with a protection pad on the cross bar. The handlebars without cross member must be equipped with a protection pad located in the middle of the handlebars, covering widely the handlebars clamps.

33.05

Exposed handlebar ends must be plugged with a solid material or rubber covered.

33.08

Solid stops (other than a steering damper) must be fixed in order to assure a minimum space of 30 mm between the handlebars with its levers and the fuel tank when on full lock to prevent trapping the rider's fingers.

33.09

Handlebar clamps must be very carefully radiused and engineered so as to avoid fracture points in the bar.

33.10

If hand protectors are used they must be of a shatter-resistant material.

33.11

The repair by welding of light alloy handlebars is prohibited.

01.35 CONTROL LEVERS

35.01

All handlebar levers (clutch, brake, etc.) must be in principle ball ended (diameter of this ball to be at least 16 mm). This ball can also be flattened, but in any case the edges must be rounded (minimum thickness of this flattened part 14 mm). These ends must be permanently fixed and form an integral part of the lever.

35.03

Each control lever (hand and foot levers) must be mounted on an independent pivot.

35.04

The brake lever if pivoted on the footrest axis must work under all circumstances, such as the footrest being bent or deformed.

01.37 THROTTLE CONTROLS

37.01

Throttle controls must be self closing when not held by the hand.

37.02 Ignition cut-out switches

For specific details, refer to this article of each discipline (CMS, CTR, CER, CCP).

37.03

Solo motorcycles must be equipped with a functional ignition kill switch or button mounted on either right or left side of handlebar (within reach of the hand while on the hand grips) that is capable of stopping a running engine (for Track Racing motorcycles, please refer to this article in the CCP section).

01.39 FOOTRESTS

For specific details, refer to this article of each discipline (CMS, CTR, CER, CCP).

01.41 BRAKES

41.01

All motorcycles must have at least 2 efficient brakes (one on each wheel) operated independently and operating concentrically with the wheel.

41.02

Vehicles in Group B must be fitted with at least 2 efficient brakes operating on at least 2 of the wheels and operated independently and operating concentrically with the wheels.

01.43 MUDGUARDS AND WHEEL PROTECTION

Motorcycles must be fitted with mudguards.

43.01

Mudguards must project laterally beyond the tyre on each side.

43.02

The front mudguard must cover the circumference of the wheel at an angle sufficient enough to protect the rider from mud.

For specific details, refer to this article of each discipline (CMS, CTR, CER, CCP).

01.45 STREAMLINING

No type of streamlining is allowed (see diagrams), with the exception of motorcycles in Cross Country Rallies.

Radiator covers (shields) must be made of flexible materials only (i.e. plastic).

01.47 WHEELS, RIMS, TYRES**47.01**

All tyres will be measured mounted on the rim at a pressure of 1 kg/cm (14 lb./sq.in.); measurements taken at a tyre section located 90° from the ground.

47.02

Any modification to the rim or spokes of an integral wheel (cast, moulded, riveted) as supplied by the manufacturer or of a traditional detachable rim other than for spokes, valve or security bolts is prohibited except for tyre retention screws sometimes used to prevent tyre movement relative to the rim. If the rim is modified for these purposes, bolts, screws, etc., must be fitted.

01.49 TYRES

For specific details, refer to this article of each discipline (CMS, CTR, CER, CCP).

01.53 SPECIFICATIONS FOR SIDECARS

(for Sidecars in Track Racing, please refer to the same article in the same section)

53.02

The drive shall be transmitted to the ground only through the rear wheel of the motorcycle.

53.06

Handlebars must be firmly secured to the forks. They must be at a height above the mid point in the seat.

A steering head must be fitted which like the handlebar must not be attached to the unsprung part of the front wheel suspension.

53.07

To reduce the torque in the steering it is allowed to displace the front wheel and the rear wheel leaving a maximum width of 75 mm between them.

53.08

The fuel tank must be sufficiently and independently protected from the ground.

53.09

Articulated Sidecars are strictly forbidden.

53.10

The Sidecar must be fixed to the motorcycle in at least three points, if it is not an integral part of the chassis.

The fixing points must not allow movement at the joints. If the angle of the inclination is changeable, it must be locked in such a way that it is completely secured and not only clamped on.

53.13

A structure of crossed belts or a metallic grid must be fitted to fill the opening between the wheels and the sidecar, to prevent the riders' foot from accidentally touching the ground.

53.14

The minimum dimensions of a Sidecar available for passenger accommodation are:

Length: 1000 mm
Width: 400 mm

Height of the screen protecting the passenger: 300 mm minimum (see diagram N).

53.15

The ground clearance of a machine measured when the machine is loaded must not be less than 175 mm.

53.16

For Sidecars, the rear wheel and the Sidecar wheel must be covered or protected with a solid material.

53.20

The distance between the tracks left by the centre lines of the rear motorcycle wheel and the Sidecar wheel must be at least: 800 mm and not more than 1150 mm.

53.21

On the opposite side of the Sidecar, the exhaust pipe must not extend more than 330 mm from the centre of the machine. On the other side, the exhaust pipe must not extend beyond the width of the Sidecar (see diagram N). The furthest extremity of the exhaust pipe must not exceed the vertical line drawn at a tangent to the rear edge of the rear motorcycle tyre or the rear edge of the Sidecar platform whichever is shorter.

01.55 NUMBER PLATES

For specific details, refer to this article of each discipline (CMS, CTR, CER, CCP).

01.63 FUEL, OIL AND COOLANTS

All motorcycles must be fuelled with unleaded petrol, as this term is generally understood (with the exception of Track Racing, four stroke – single cylinder engines).

63.01 Physical properties for unleaded fuel

63.01.1 Unleaded petrol must comply with the FIM specification.

63.01.2 Unleaded petrol (**incl. E10**) will comply with the FIM specification if:

(a) It has the following characteristics:

Property	Units	Min.	Max.	Test Method
RON		95.0	102.0	EN ISO 5164
MON		85.0	90.0	EN ISO 5163
Oxygen	% (m/m)		4.0	EN 13132 or 14517
Nitrogen	% (m/m)		0.2	ASTM D 4629
Benzene	% (V/V)		1.0	EN 238 or EN 14517
Vapour pressure (DVPE)	kPa		95.0	EN 13016-1
Lead	g/L		0.005	EN 237 or ICP-OES
Manganese	g/L		0.005	ICP-OES
Density at 15°C	kg/m ³	720.0	775.0	EN ISO 12185
Oxidation stability	minutes	360		EN ISO 7536
Existent gum	mg/100 mL		5.0	EN ISO 6246
Sulphur	mg/kg		10.0	EN ISO 20846 or 20884
Copper corrosion	rating		class 1	EN ISO 2160
Distillation:				
E at 70°C	% (V/V)	22.0	50.0	EN ISO 3405
E at 100°C	% (V/V)	46.0	71.0	EN ISO 3405
E at 150°C	% (V/V)	75.0		EN ISO 3405
Final Boiling Point	°C		210	EN ISO 3405
Residue	% (V/V)		2.0	EN ISO 3405
Appearance	Clear and bright			Visual inspection
Ethanol (1)	% (V/V)		10	EN 13132 or 14517
Olefins	% (V/V)		18.0	EN 14517 or 15553
Aromatics	% (V/V)		35.0	EN 14517 or 15553
Total diolefins	% (m/m)		1.0	GCMS/HPLC

(1) Shall conform to EN 15376

- (b) The total of individual hydrocarbon components present at concentrations of less than 5 % m/m must constitute at least 30 % m/m of the fuel. The test method will be gas chromatography and/or GC/MS.
- (c) The total concentration of naphthenes, olefins and aromatics classified by carbon number must not exceed the values given in the following table:

%	C4	C5	C6	C7	C8	C9+
Naphthenes	0	5	10	10	10	10
Olefins	5	20	20	15	10	10
Aromatics	-	-	1.2	35	35	30

The total concentration of bicyclic naphthenes and bicyclic olefins may not be higher than 1% (m/m). The test method used will be gas chromatography.

- (d) Only the following oxygenates are permitted:

Methanol. Ethanol. Iso-propyl alcohol. Iso-butyl alcohol. Methyl tertiary butyl ether. Ethyl tertiary butyl ether. Tertiary amyl methyl ether. Di-isopropyl ether. N-propyl alcohol. Tertiary-butyl alcohol. N-butyl alcohol. Secondary-butyl alcohol.

- (e) Manganese is not permitted in concentrations above 0.005 g/l. For the present this is solely to cover possible minor contamination by other fuels. The fuel will contain no substance that is capable of an exothermic reaction in the absence of external oxygen.

Lead replacement petrols, although basically free of lead, are not an alternative to the use of unleaded petrol. Such petrols may contain unacceptable additives not consistent with the FIM Fuel Regulations.

63.01.3 Ethanol E85 will comply with the FIM specification if:

a) It has the following characteristics:

Property	Units	Min.	Max.	Test Method
RON		95.0	110	EN ISO 5164
MON		85.0	100	EN ISO 5163
Vapour pressure (DVPE)	kPa	35.0	95.0	EN 13016-1
Lead	g/L		0.001	ICP-OES
Manganese	g/L		0.001	ICP-OES
Oxidation stability	Minutes	360		EN ISO 7536
Existent gum	mg/100 mL		5.0	EN ISO 6246
Sulphur	mg/kg		10.0	EN ISO 20846 or 20884
Copper corrosion	Rating		Class 1	EN ISO 2160
Distillation:				
Final Boiling Point	°C		210	EN ISO 3405
Residue	% (V/V)		2	EN ISO 3405
Appearance	Clear and bright			Visual inspection
Ethanol + higher alcohols	% (V/V)	75		EN 13132 or 14517
Higher alcohols (C3-C8)	% (V/V)		2.0	EN 13132 or 14517
Methanol	% (V/V)		1.0	EN 13132 or 14517
Ethers (5 or more C atoms)	% (V/V)		5.2	EN 13132 or 14517
Unleaded petrol as specified in 2.10.1.2	% (V/V)	14	25	
Water	% (V/V)		0.3	EN 12937
Inorganic chloride	mg/L		1	EN 15484
Acidity (as acetic acid)	% (m/m) (mg/L)		0.005 (40)	EN 15491

63.02 Oil

For oil used in two stroke mixtures, the following tolerances on the fuel specifications will be allowed:

• Density at 15°C	Plus/minus 30 kg/m ³
• Distillation residue	Not controlled

Any infringement of the fuel specifications will automatically result in the exclusion of the competitor from the entire meeting (see also Sporting Code Art. 140.1). The result of the competitors' fuel sample analysis (A or B Sample) more favourable to the competitor will be taken into account (See also Art. 63.05.3).

If the fuel available locally for the event is not of a sufficient quality for use by competitors, the FMN of the organising country must ask the FIM for a waiver in order to enable the use of fuel not corresponding to the characteristics defined above.

63.03 Air

Only ambient air may be mixed with the fuel as an oxidant.

63.04 Primary Tests

63.04.1 In all FIM Championship and Prizes, the FIM may require tests of fuels to be administered before, or at the time of delivery to, an event at which such fuels are to be used.

63.04.2 FIM may request any person or organisation, being a potential supplier of fuel, to submit a sample for testing for conformity with the fuel specifications in Art. 63.01.

63.05 Fuel Test Procedures

63.05.1 Fuel tests may be administered at any time and place during the course of any event under the authority of the FIM.

63.05.2 The CTI Bureau, in consultation with the relevant Commission President, has sole authority to, and may, direct the administration of fuel tests during the course of an FIM Championship or Prize Event. Such direction must be by written document (Fuel Test Order) which must be delivered to the Jury President (**or the Race Direction where applicable**) before the meeting. The Jury President (**or the Race Direction where applicable**) must deliver the Fuel Test Order to the Chief Technical Steward for the meeting who is responsible for the administration of the fuel tests. The Fuel Test Order must nominate:

- (a) The criteria (which may be random) for selection of the machines from which samples are to be taken; and
- (b) The officials who must administer the tests.
- (c) At least 3 of the characteristics specified in Arts. 63.01 and 63.02 to be the subject of the tests, or only 1 characteristic when using an ASTM approved "short test" or "field test method" for the detection of only one of the characteristics in a fuel sample.

63.05.3 Fuel tests must be administered according to the Fuel Test Order and must comply with the following procedures:

- (a) Only nominated officials may take samples.
- (b) Containers for holding samples:
 - (i) must be clean and constructed of robust, fuel non reactive, impermeable material.
 - (ii) must be sealable;
 - (iii) must have provision for identification.
- (c) Equipment used for the extraction of fuel from machines must be clean and constructed of fuel non-reactive material.
- (d) The FMNRs must ensure that there is a supply of at least 12 containers (12 X 1 litre each).
- (e) Each sample must be divided into two and placed in separate containers, (2 samples of maximum 1 litre each). Each sample may be initially tested for one of the characteristics, using an ASTM approved field test method. The results obtained from such a test must be given immediately to the International Jury. The containers must be immediately sealed and identified by reference to the machine from which the sample was taken.

This information must be entered on a certificate (FIM Fuel Sample Certificate) which must certify the date, place and time of taking the sample, the identity of the machine from which the sample was taken, and the identity of its rider.

- (f) Both samples (sample A and sample B) must remain in the control of the Technical Steward. The rider or the representative of the rider/ team must sign the FIM Fuel Sample Certificate acknowledging that a sample was taken, and must be given a copy of the Certificate.
- (g) At the end of the meeting the Technical Steward must deliver both samples (sample A and sample B) to a courier authorised by the FIM, Jury President or the Technical Steward. The Technical Steward must return a copy of the Fuel Sample Certificate, signed by the courier, to the Jury President.

- (h) The authorised courier must deliver both samples (sample A and sample B), together with copies of the relevant Fuel Sample Certificates, to an FIM authorised laboratory, where they must be tested for content in accordance with standard scientific procedures.
- (i) The results obtained from such testing must be attached to the laboratory's copy of the Fuel Sample Certificate and delivered to the FIM as soon as practicable after the results have been obtained.
- (j) In case of non conformity to the rules, the FIM must as soon as practicable after receipt of the results notify:
 - (i) the relevant riders or team representatives;
 - (ii) the relevant FMNR;
 - (iii) the Jury President for the relevant meeting.

63.05.4 The FIM may authorise one or more named laboratories for testing fuels. Such authorisation must be by written document, distributed to all FMNRs.

63.05.5 A Jury may direct the administration of fuel tests during the course of any international event other than an FIM Championship or Prize Event. Such direction must be by Fuel Test Order which must be delivered to the Technical Steward. Such Fuel Test Order has the same authority as if it had been issued by the CTI Bureau under Art. 63.05.2. The procedures for the administration of fuel tests under this Article must comply with the procedures under Arts. 63.05.2 and 63.05.3.

63.05.6 For tests under Art. 63.04 all characteristics specified in Art. 63.01 must be present for the tested fuel to comply.

63.05.7 For tests under Arts. 63.05.2 and 63.05.5 tested fuel must comply with the characteristics specified in the relevant Fuel Test Order.

63.06 Fuel Test Costs

63.06.1 The costs of fuel tests conducted under Arts. 63.04.1, 63.04.2 and 63.05.2 will be paid by the FIM.

63.06.2 The costs of fuel tests conducted under Art. 63.05.5. will be paid by the organiser of the event.

63.06.3 Where a fuel test is ordered by a Jury in relation to a protest, the party which loses the protest must bear the entire cost of the fuel test, or such proportion thereof as is directed by the Jury.

01.65 EQUIPMENT AND PROTECTIVE CLOTHING **Clothing and footwear**

During practising and racing, riders and passengers must wear the protective clothing and footwear

For specific details, refer to this article of each discipline (CMS, CTR, CER, CCP).

65.07 Material equivalent to leather

The following characteristics of the material must be at least equivalent to 1.5 mm of cowhide (not split leather):

- 65.07.1** Fire retardant quality
- 65.07.2** Resistance to abrasion
- 65.07.3** Coefficient of friction against all types of asphalt
- 65.07.4** Perspiration absorbing qualities
- 65.07.5** Medical test – non toxic and non-allergenic
- 65.07.6** Fabric of a quality that does not melt.

65.07.7 Clothing in material other than leather must bear a sticker or label which says "in conformity with the FIM rules". This label must be sewn or attached to the clothing in a permanent way.

65.08 Approval

The clothing manufacturer is responsible for ensuring that the products and materials that carry his name conform to these rules. The FIM cannot be held liable for any injuries that a rider or passenger may sustain from their use.

01.67 WEARING OF HELMETS

It is compulsory for all participants taking part in practice and races to wear a protective helmet. The helmet must be properly fastened, be of a good fit, and be in good condition. The helmet must have a chin strap type 'retention system'.

Helmets constructed with an outer shell of more than one piece are permitted, provided that, in case of emergency; they can be quickly and easily removed from the rider's head by releasing or cutting the chin strap only.

All helmets must be marked with one of the official international standard marks mentioned in Art. 01.70 or the Approval Mark (stamp) of the FMN of the rider. Helmets marked by an FMN must comply with one of the International Standards listed in Art. 01.70 before approval by an FMN.

Failure to observe the above rules will entail exclusion.

01.69 HELMET OPERATIVE INSTRUCTIONS

69.01

Scrutineers, under the supervision of the Chief Technical Steward, may check prior to practice and the races that all helmets meet the technical requirements.

69.02

If a helmet does not meet the technical requirements and is found to be defective, the Technical Steward must remove all approval marks and retain the helmet until the end of the event. The rider must submit another helmet for approval by the Technical Steward. After an accident involving impact, the helmet must be presented to the Technical Steward for examination (see also Art. 77.02.14).

69.03

All helmets must be intact and no alteration must have been made to their construction. After an accident involving impact the helmet must be presented to the Technical Steward for examination.

69.04

The Technical Steward and/or the Technical Scrutineer may perform the following checks before the rider is permitted to take part in practice of the race:

69.04.1 That the helmet fits well on the rider's head,

69.04.2 That it is not possible to slip the retention system over the chin, when fully fastened,

69.04.3 That it is not possible to pull the helmet over the rider's head by pulling it from the back of the helmet.

01.70 RECOGNISED INTERNATIONAL HELMET APPROVAL MARKS

- Europe ECE 22-05 'P', 'NP' or 'J'
- Japan JIS T 8133 : 2000
- USA SNELL M 2005

(see International Helmet Standards in diagram section)

01.71 EYE PROTECTION

The use of glasses, protective goggles as well as helmet visors and 'tear off's' is permitted. The material used for eye protectors and glasses must be made of shatter-proof material. Helmet visors must not be an integral part of the helmet.

Eye protectors which cause visual disturbance (scratched etc.) must not be used.

01.73 NATIONAL COLOURS FOR HELMETS

(with the exception for the CCP)

The following National colours are approved:

Andorra	FMA	White with vertical blue, yellow and red bands
Argentina	CAMOD	White with blue horizontal band
Australia	MA	Green and yellow sides, red, white & blue representation of the Australian flag across the top
Austria	OeAMTC	Bright red with a 60 mm wide black band and the label of the OeAMTC in a white field on the front side
Belgium	FMB	Yellow
Brazil	CBM	Yellow and green
Bulgaria	BMF	Green and red
Canada	CMA	White and 3 Red Maple leaves, one on front and one on each side
Chile	FMC	Red with blue band and yellow stars
China	CMSA	Red and yellow
Czech Republic	ACCR	Blue with red, white and blue border
Denmark	DMU	Red and white
Finland	SML	White with blue cross
France	FFM	Blue
Germany	DMSB	White with black border
Great Britain	ACU	Green
Greece	ELPA	White with blue border
Hungary	MAMS	Red and green
Ireland	MCIU	Green and orange
Italy	FMI	Red with one green and one white horizontal band
Japan	MFJ	White with red circle on top
Kenya	KMSF	Black, Red, Green, with white bands and the country name KENYA on both sides.
Luxembourg	MUL	Purple
Mexico	FMM	White with green and red border
Monaco	MCM	Blue and white
Netherlands	KNMV	Orange
New Zealand	MNZ	White with black kiwi on front
Norway	NMF	Red and blue
Peru	FPEM	Red with 75 mm wide white strips and blue and yellow chequered border
Poland	PZM	White with red band
Portugal	FNM	White
Rumania	FRM	Black with vertical blue, yellow and red bands with national emblem.
Russia	MFR	White with a red border and a vertical red band with star
San Marino	FSM	White with the San Marino National emblem
Slovakia	SMF	Blue, red and white
South Africa	MSA	Black, green, blue and red with yellow and white bands
Spain	RFME	Yellow and red
Sweden	SVEMO	Blue and yellow
Switzerland	FMS	Red with white cross
Uruguay	FUM	Light blue
USA	AMA	Blue with 2 white bands

In addition to this, for the holders of World or National championships, a central band 50 mm wide from front to back across the top carrying the national colours or a rainbow is admitted.

In competitions between national teams, helmets must be the same colour for each team member and must include in the overall helmet colour scheme, their national flag colours, presented in stripes, bands or other design.

01.75 BADGE OF THE FIM

Under certain circumstances the FIM may permit the use of the FIM badge on certain equipment in order to show that the latter conforms with the standards laid down by the FIM. When this authorisation is granted and provided the equipment on which it appears is in good condition, the badge is then the guarantee of the conformity with the standard set by the FIM.

01.76 NUMBER SASHES (BIBS)

For specific details, refer to this article of each discipline (CMS, CTR, CER, CCP).

01.77 CONTROL

77.01 Verification

General

A rider is at all times responsible for his machine.

77.01.1 The Chief Technical Steward must be in attendance at an event 1 hour before technical verifications are due to begin. He must inform the Clerk of the Course, Jury President and CTI Delegate, if present, of his arrival.

77.01.2 He must ensure that all technical stewards, appointed for the event, carry out their duties in a proper manner.

77.01.3 He shall appoint the technical stewards to individual posts for the race, practices and final control.

77.01.4 Technical inspections will only be carried out when the technical specification form of the motorcycle has been presented by the Organiser.

77.01.5 The rider, or his mechanic, must be present with the machine for technical control within the time limits stated in the Supplementary Regulations. On request of the Technical Steward, the riders must present themselves to the technical verification.

77.01.6 The Chief Technical Steward must inform the Clerk of the Course/ Jury President of the results of the technical control. The Chief Technical Steward will then draw up a list of accepted machines and submit this list to the Clerk of the Course.

77.01.7 The Chief Technical Steward has the right to look/ inspect any part of the motorcycle at any time of the event.

77.02

Any rider failing to report as required below may be excluded from the meeting. The Clerk of the Course may forbid any person who does not comply or any rider who can be a danger to other participants or to spectators, to take part in the practising or in the races.

77.02.1 The technical control must be carried out in accordance with the procedure and times fixed in the Disciplines' Rules and the Supplementary Regulations of the event. The maximum number of persons permitted to be present at the technical verification is the rider, plus two others. For Team events, the Team Manager is also allowed.

77.05 Dangerous machines

If, during practising or the race, a Technical Steward finds that a machine is defective and might constitute a danger to other riders, he must immediately notify the Clerk of the Course or his deputy. It is their duty to exclude such a machine from either the practice or from the race itself.

01.79 SOUND CONTROL (not applicable to Trial machines)

Sound will be controlled to limits as stated in Art. 79.11.

For the initial sound control and technical inspection, a rider (or his mechanic) shall present only one spare silencer per machine.

Other spare silencers may be presented after all participants have presented their motorcycles, or on the following days of the event.

79.01

With the microphone placed at 50 cm from the exhaust pipe at an angle of 45° measured from the centre-line of the exhaust end and at the height of exhaust pipe, but at least 20 cm above the ground. If this is not possible, the measurement can be taken at 45° upwards.

79.02

During the sound test only, every motorcycle must be equipped with an extension (min. 30 cm) to the spark plug cable, if requested by the Chief Technical Steward. One end of this extension must be plugged into the original spark plug cap whilst the other end has another spark plug cap and fitted normally on the spark plug.

During a sound test, machines not equipped with a gear box neutral must be placed on a stand.

During the sound test, only the rider may take place on the machine in the normal riding position and operate the throttle. No other team personnel may influence the sound test.

79.03

The silencers will be marked when they are checked and it is not allowed to change them after the verification, except for any spare silencer which has also been checked and marked.

All silencers will be checked and marked, once they have successfully passed the sound check. The end opening of the silencer shall remain unmodified once it has been checked and marked.

Silencers fitted with adapters aimed to reduce the sound level shall be permanently fitted.

79.04

The rider shall keep his engine running and shall increase the engine speed until it reaches the specified Revolutions Per Minute (RPM). Measurements must be taken when the specified RPM is reached.

79.05

The RPM depends upon the mean piston speed corresponding to the stroke of the engine.

The RPM will be given by the relationship:

$$N = \frac{30,000 \times cm}{l}$$

in which N = prescribed RPM of engine
 cm = fixed mean piston speed in m/s
 l = stroke in mm

79.06

For specific details, refer to this article of each discipline (CMS, CTR, CER, CCP).

79.07

The sound level for engines with more than one cylinder will be measured on each exhaust end.

79.08

A machine which does not comply with the sound limits can be presented several times at pre-race control.

79.11 **Sound limits in force**

For specific details, refer to this article of each discipline (CMS, CTR, CER, CCP).

79.12

The surrounding sound should not exceed 90 dB/A within a 5 metres radius from the power source during tests.

79.13

Apparatus for sound control must be to international standard IEC 651, Type 1 or Type 2.

The sound level meter must be equipped with a calibrator for control and adjustment of the meter during periods of use.

79.14

The "slow response" setting must always be used.

79.15

Due to the influence of temperature on sound tests, all figures are correct at 20°C. For tests taken at temperatures below 10° C there will be a + 1 dB/A tolerance

For tests below 0°C, a + 2 d/BA tolerance.

79.16 Sound control during and after the competition

In a competition which requires a final examination of machines before the results are announced, this examination must include a sound control measurement of at least three machines chosen at the discretion of the Clerk of the Course in co-operation with the Chief Technical Steward

01.80 GUIDELINES FOR USE OF SOUND LEVEL METERS**80.01**

The Sound Control Officer (NCO) must arrive in sufficient time for discussions with the Clerk of the Course and other Technical Officials in order that a suitable test site and testing policy can be agreed.

80.02

Sound level measuring equipment must include a compatible calibrator, which must be used immediately before testing begins and always just prior to a re-test if a disciplinary sanction may be imposed.

Two sets of equipment must be available in case of failure of tachometer, sound level meter or calibrator during technical control.

80.03

Before testing, the NCO should if possible liaise with a maximum of two holders of FIM Entrant's or Manufacturer's licences, or team managers, who have sound test equipment including calibrators, in order to agree the accuracy of the official sound level meter.

80.04

Tests should not take place in rain or excessively damp conditions. Machines considered excessively noisy must be individually tested if conditions allow.

80.05

In other than moderate wind, machines should face forward in the wind direction. (Mechanical sound will blow forward, away from microphone).

80.06

'Slow' meter response must be used.

80.07

'A' weighted setting on sound level meter.

80.08

Always round down meter reading, that is: 100.9 dB/A = 100 dB/A.

80.09 Corrections

Type 1 meter : deduct 1 dB/A

Type 2 meter : deduct 2 dB/A

80.10 Temperature

Ambient temperature:

Below 10° Celsius : deduct 1 dB/A

Below 0° Celsius : deduct 2 dB/A.

All tolerances are accumulative. Action taken will depend on the sporting discipline concerned, and decisions taken during prior discussions with the Clerk of the Course.

01.81 TIMEKEEPING

Since 1.1.1993, the responsibility for Timekeeping has been referred to the each Sporting Commission.

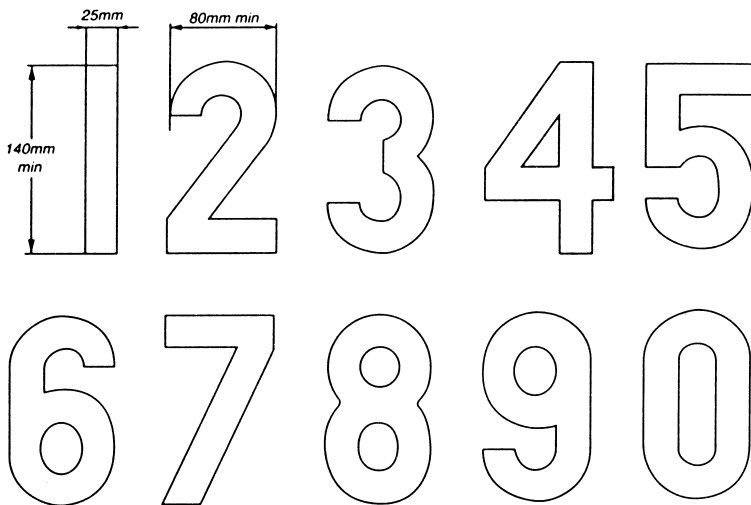
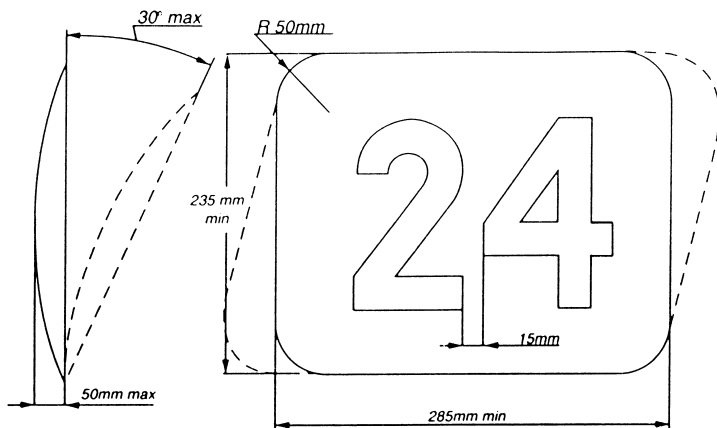

Futura Heavy

0 1 2 3 4 5 6 7 8 9

Futura Heavy Italic

0 1 2 3 4 5 6 7 8 9

Univers Bold

0 1 2 3 4 5 6 7 8 9

Univers Bold Italic

0 1 2 3 4 5 6 7 8 9

Oliver Med.

0 1 2 3 4 5 6 7 8 9

Oliver Med. Italic

0 1 2 3 4 5 6 7 8 9

Franklin Gothic

0 1 2 3 4 5 6 7 8 9

Franklin Gothic Italic

0 1 2 3 4 5 6 7 8 9

TEN FITTING TESTS FOR HELMETS
DIX TESTS D'ADAPTATION POUR LES CASQUES

1. *Obtain correct size by measuring the crown of the head*
Avoir la bonne grandeur en mesurant le sommet de la tête
2. *Check there is no side to side movement*
Vérifier qu'il n'y ait pas de déplacement d'un côté à l'autre
3. *Tighten strap securely*
Serrer solidement la jugulaire
4. *With head forward, attempt to pull up back of helmet to ensure helmet cannot be removed this way*
Tête en avant, essayer de soulever le casque pour s'assurer qu'il ne peut pas être enlevé de cette façon



5. *Check ability to see clearly over shoulder*
Vérifier si vous pouvez voir clairement par-dessus l'épaule
6. *Make sure nothing impedes your breathing in the helmet and never cover your nose or mouth*
S'assurer que rien ne gêne votre respiration dans le casque et ne jamais couvrir le nez ou la bouche
7. *Never wind scarf around neck so that air is stopped from entering the helmet. Never wear scarf under the retention strap*
Ne jamais enrouler une écharpe autour du cou, car cela empêche l'air d'entrer dans le casque. Ne jamais porter d'écharpe sous la jugulaire
8. *Ensure that visor can be opened with one gloved hand*
S'assurer que la visière peut être ouverte avec une main gantée
9. *Satisfy yourself that the back of your helmet is designed to protect your neck*
S'assurer que l'arrière de votre casque a une forme telle qu'il vous protège la nuque
10. *Always buy the best you can afford*
Toujours acheter le meilleur que vous pouvez vous offrir

INTERNATIONAL HELMETS STANDARDS

NORMES INTERNATIONALES DES CASQUES

ECE 22 - 05 "P" (EUROPE)

The ECE mark consists of a circle surrounding the letter E followed by the distinguishing number of the country which has granted approval.



E1 for Germany, **E2** for France, **E3** for Italy, **E4** for Netherlands, **E5** for Sweden, **E6** for Belgium, **E7** for Hungary, **E8** for Czeck Republic, **E9** for Spain, **E10** for Yugoslavia, **E11** for UK, **E12** for Austria, **E13** for Luxembourg, **E14** for Switzerland, **E15** (- vacant), **E16** for Norway, **E17** for Finland, **E18** for Denmark, **E19** for Roumania, **E20** for Poland, **E21** for Portugal, **E22** for the Russian Federation, **E23** for Greece, **E24** for Ireland, **E25** for Croatia, **E26** for Slovenia, **E27** for Slovakia, **E28** for Bielo Russia, **E29** for Estonia, **E30** (- vacant), **E31** for Bosnia and Herzegovina, **E32** for Letonie, **E34** for Bulgaria, **E37** for Turkey, **E40** for Macedonia, **E43** for Japan, **E44** (- vacant), **E45** for Australia, **E46** for Ukraine, **E47** for South Africa, **E48** New Zealand.

Below the letter **E**, the **approval** number should always begin with 05. Below the approval number is the serial production number. (Label on retention system or comfort interior).

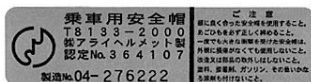

(JAPAN) JIS T 8133 : 2000

(Label affixed inside the helmet).



(USA) SNELL M2005

(Label affixed inside the helmet).

For more details consult the F.I.M. Technical Rulebook

Technical Rules
Règlements Techniques

Enduro

(Including Rules for Cross-Country Rallies)
(Règlements pour Rallyes Tout Terrain inclus)

TECHNICAL RULES FOR ENDURO (CER)

TABLE OF CONTENTS

01.01	INTRODUCTION	91
01.03	FREEDOM OF CONSTRUCTION	91
01.05	CATEGORIES AND GROUPS OF MOTORCYCLES	91
01.07	CLASSES	91
01.11	MEASUREMENT OF CAPACITY	92
01.17	SUPERCHARGING	92
01.18	TELEMETRY.....	92
01.21	DESIGNATION OF MAKE	92
01.23	DEFINITION OF A PROTOTYPE	93
01.25	GENERAL SPECIFICATIONS	93
01.26	DEFINITION OF A FRAME OF A SOLO MOTORCYCLE	93
01.27	STARTING DEVICES	93
01.31	EXHAUST PIPES	93
01.33	HANDLEBARS	94
01.35	CONTROL LEVERS	94
01.37	THROTTLE CONTROLS	94
01.39	FOOTRESTS	94
01.41	BRAKES	94
01.43	MUDGUARDS AND WHEEL PROTECTION	94
01.45	STREAMLINING	95
01.47	WHEELS, RIMS AND TYRES	95
01.51	ENDURO TYRES	95
01.53	ADDITIONAL SPECIFICATIONS FOR SIDECARS	96
01.55	NUMBER PLATES	97
01.56	LIGHTING, WARNING EQUIPMENT AND SPEEDOMETERS CROSS-COUNTRY RALLY MOTORCYCLES	99
01.58	DISCIPLINE SPECIFICATIONS – PRODUCTION CATEGORY ...	101
01.59	CERTIFICATION REQUIREMENTS	106
01.60	DISCIPLINE SPECIFICATIONS – SUPERPRODUCTION CATEGORY	106
01.61	QUAD CATEGORY	108
01.63	FUEL, FUEL/OIL MIXTURES	112
01.65	EQUIPMENT AND PROTECTIVE CLOTHING	112
01.67	WEARING OF HELMETS	112
01.69	HELMET OPERATIVE INSTRUCTIONS	112
01.70	RECOGNISED INTERNATIONAL APPROVAL MARKS	113
01.71	EYE PROTECTION	113
01.73	NATIONAL COLOURS FOR HELMETS	113
01.75	BADGE OF THE FIM	113

01.76	NUMBER SASHES (BIBS)	113
01.77	CONTROL	114
01.79	SOUND CONTROL	116
01.80	GUIDELINES FOR USE OF SOUND LEVEL METERS	119
01.81	TIMEKEEPING	119
DIAGRAMS		120

01.01 INTRODUCTION

For the main article, refer to the same number in the General section.

01.03 FREEDOM OF CONSTRUCTION

For the main article, refer to the same number in the General section.

01.05 CATEGORIES AND GROUPS OF MOTORCYCLES

For the main article, refer to the same number in the General section.

01.07 CLASSES

Groups are again separated into classes according to cylinder capacities as detailed below. Generally, these classes must be observed for all meetings. (However, see Arts. 061.41 and 062.21 of the Enduro rules for the ISDE and the Enduro World Championship).

Category I

For the main article, refer to the same number in the General section.

Group A1 Motorcycles

Class (cc)	over (cc)	up to (cc)
50	–	50
80	50	85
100	85	100
125	100	125
175	125	175
250	175	250
450	250	450
500	450	500
750	500	750
1000	750	1000
1300	1000	1300

Groups B1, B2 Sidecars

Same as groups A1 and A2 over 175 cc.

Category II

- Group C – Special 2 wheel driven motorcycles
- Group D – Special 3 wheel, two wheel driven motorcycles

- Group E – Snowmobiles
- Group F – Sprinters and Dragsters
- Group G – Quad racers: Four wheeled balloon tyred off-road vehicles having a wheel at each diagonal extremity.
Propelled by the action of two wheels (2 wheel driven).
The engine crankcases shall not be located behind the rider.
Only one rider sits astride.
The steering is done by means of a handlebar.
Same classes as Category I, Group A1.
- Group H – Quad racers: only difference – propelled by the action of four wheels (4 wheel driven)
- Group I – –

Category III

- Group J – Electric Vehicles (see Art. 01.82 in the Road Racing Technical Rules).

01.11 MEASUREMENT OF CAPACITY

For the main article, refer to the same number in the General section.

01.17 SUPERCHARGING

For the main article, refer to the same number in the General section.

01.18 TELEMETRY

For the main article, refer to the same number in the General section.

01.21 DESIGNATION OF MAKE

For the main article, refer to the same number in the General section.

01.23 DEFINITION OF A PROTOTYPE

For the main article, refer to the same number in the General section.

01.25 GENERAL SPECIFICATIONS

For the main article, refer to the same number in the General section.

01.26 DEFINITION OF A FRAME OF A SOLO MOTORCYCLE

For the main article, refer to the same number in the General section.

26.01

Every motorcycle in the 'parc-fermé' must be equipped with a side-stand. The side-stand must be fitted, either on the frame or on the swing arm.

01.27 STARTING DEVICES

Starting devices are compulsory.

01.29 OPEN TRANSMISSION GUARDS

29.01 A guard must be fitted to the countershaft sprocket.

29.02 A chain guard must be fitted in such a way to prevent trapping between the lower chain run and the final driven sprocket at the rear wheel.

01.31 EXHAUST PIPES

Exhaust pipes and silencers must fulfil all the requirements concerning sound control. (see also Art. 01.79).

31.02

Any NON ORIGINAL valve systems installed on the exhaust system in view of interfering with (or modifying) the sound level meter test is forbidden. Only exhaust valve systems (i.e: Exup, etc.) provided by the manufacturer on the manifold, are authorised. The setting is free.

31.03

The extremity of the exhaust pipes for solo motorcycles must not pass the vertical tangent of the rear tyre (see diagram S).

01.33 HANDLEBARS

For the main article, refer to the same number in the General section.

33.10

If hand protectors are used they must be of a shatter-resistant material and have a permanent opening for the hand.

33.11

The repair by welding of light alloy handlebars is prohibited.

01.35 CONTROL LEVERS

For the main article, refer to the same number in the General section.

01.37 THROTTLE CONTROLS

For the main article, refer to the same number in the General section.

01.39 FOOTRESTS

For the main article, refer to the same number in the General section.

01.41 BRAKES

For the main article, refer to the same number in the General section.

01.43 MUDGUARDS AND WHEEL PROTECTION

For the main article, refer to the same number in the General section.

43.02

The front mudguard must cover at least 100° of the circumference of the wheel. The angle formed by one line drawn from the front edge of the mudguard to the centre of the wheel and one drawn horizontally through the centre of the wheel must be between 45° and 60°.

43.03

The rear mudguard must cover at least 120° of the circumference of the wheel. The angle formed by two lines, one drawn from the rear edge of the mudguard to the centre of the wheel and one drawn horizontally through the centre of the wheel shall not exceed 20°.

The angle (20° max.) for the rear mudguard shall be measured with the rider sitting on the motorcycle (See diagram S).

01.45 STREAMLINING

For the main article, refer to the same number in the General section.

01.47 WHEELS, RIMS, AND TYRES

For the main article, refer to the same number in the General section.

01.51 TYRES FOR ENDURO MOTORCYCLES

51.01

The front tyre dimensions are free.

51.03

Tyres with metal studs (with the exception of winter events and approved by the International Jury – see Art 51.06), spikes, chains or any other anti-skid devices are not permitted. Scoop or paddle tyres (continuous radial rib) are forbidden.

51.04 General

Only tyres normally available from commercial or retail sources are authorised. They shall appear on the tyre manufacturers range catalogue or tyre specification lists available to the general public. They must be manufactured to comply with the European Tyre and Rim Technical Organisation (ETRTO) requirements in respect of load and speed codes and have a minimum service description of 45 M. The tyres must have an "E" mark and/or DOT (American Department of Transportation) approval and the DOT number must be moulded on the tyre wall.

51.05 Thread pattern

The thread pattern specifications of the rear tyre is as follows: Depth of thread, measured at right angles to the tyre surface (to which all thread blocks must extend): Maximum 13 mm (See diagram S).

51.06 Tyres with studs

The use of studded tyres will be defined in the Supplementary Rules of the event. The use of studded tyres shall be approved by the International Jury, based on the state of the course.

Only studded tyres available from commercial tyre retail sources are authorised. These shall appear on the manufacturer's tyre catalogue or tyre specification list available to the general public (see Diagram S).

All dimensions of the studs, their number, method of mounting, etc., must be in accordance with the national legislation of the country where the event is held.

01.53 ADDITIONAL SPECIFICATIONS FOR SIDECARS

For the main article, refer to the same number in the General section.

01.55 NUMBER PLATES

Number plates are required for Enduro. They must be fitted as follows:

55.03

They must be rectangular shape and made from a rigid and solid material with minimum measurements 285 mm x 235 mm. (See diagram 0 in the General Section).

55.04

The plates curved not more than 50 mm out of a true plane must not be covered or bent.

55.05 Front number plates

One plate must be fixed to the front inclined not more than 30° rearwards from the vertical. The others must be placed vertically one on each side of the motorcycle facing outwards. They must be fixed in such a manner as to be clearly visible and they must not be masked by any part of the motorcycle or by the rider when seated in the driving position.

55.06

In place of separate plates, a space of equivalent size in matt colours can be painted or fixed on the bodywork.

55.07

The figures must be clearly legible and like the background must be painted in matt colours to avoid reflection from sunlight. The minimum dimensions of the letters being:

Height of figure:	140 mm
Width of figure:	80 mm
Width of stroke:	25 mm
Space between 2 figures:	15 mm

55.08

The English form for numbers must be used. That is single vertical line for the "one" and a simple sloping line without a horizontal line for the "seven". (See diagram 0).

55.09

All other number plates or markings on a motorcycle liable to cause confusion with the number must be removed before the start of a competition.

55.11 Side number plates

The side number plates must be positioned above a horizontal line drawn through the rear wheel spindle and the front edge of the plate must be behind a vertical line drawn at 200 mm to the rear of the rider's footrest.

55.12 Number plate colours

The background colours and figures vary according to the class of motorcycle and the type of competition, the the main rules being indicated in the Supplementary Regulations for each meeting.

The colours must be matt, following the RAL colour table, i.e.:

BLACK	9005
YELLOW	1003
RED	3020
GREEN	6002
WHITE	9010
PURPLE	4006

The colours to be used are:

WEC	Enduro 1	Black background	White numbers
	Enduro 2	Red background	White numbers
	Enduro 3	Yellow background	Black numbers
	Enduro Junior	Green background	White numbers
ISDE	World Trophy	Red background	White numbers
	Junior World Trophy	Green background	White numbers
	Women's World Cup	Purple background	White numbers
	Other categories	Yellow background	Black numbers

55.13

The figures must be applied to each machine by the organisers during the preliminary examination. The carrying of number plates is obligatory for the Six Days Enduro and any rider who retires during the event, must immediately remove them.

In case of a dispute concerning the legibility of numbers, the decision of the Technical Steward will be final.

01.56 LIGHTING, WARNING EQUIPMENT AND SPEEDOMETERS

Motorcycles and their equipment must comply with the national legal requirements for road traffic of the country in which the vehicle is registered and with other rules specified in the Supplementary Regulations.

The electrical generator must operate continuously and normally with respect to current and voltage during the competition and at post competition control. The electrical connections must be retained.

CROSS-COUNTRY RALLY MOTORCYCLES

Articles 01.58, 01.59, 01.60 and 01.61 Discipline Specifications

01.58 PRODUCTION CATEGORY

Based on 'mass' production (series), road legal motorcycles

01.59 CERTIFICATION REQUIREMENTS

01.60 SUPERPRODUCTION CATEGORY

Based on a 'single unit' type motorcycle or mass production motorcycles, registered for road use.

01.61 QUAD CATEGORY

GENERAL

All **vehicles from the Production, Superproduction and Quad categories** must conform in all respects to the 1968 Vienna Convention, even if the country in which the machine was manufactured is not a signatory to that Convention, and be registered for road use.

The engine must function on unleaded fuel in accordance with the FIM fuel specifications (see Art. 01.63) and be of a type equivalent to fuel from public fuel stations. **Exceptions will be mentioned in the SR of the meeting.**

Lighting equipment **for the Production, Superproduction and Quad categories** must conform in every way to the International Convention on road traffic, **moreover:**

The original headlights **and** rear lights may be modified or replaced. Extra lights may be added.

Each motorcycle/**quad** must be equipped with at least:

- A front light (min 55 watts or equivalent in 'lumen')
- A homologated rear lamp with stop light
- Additionally, a fog lamp (min 21 watts or equivalent in 'lumen'), with a minimum legal surface, may be split into two parts and may flash
- An audible horn
- Minimum one rear view mirror.

All motorcycles/**quads** must carry the necessary survival equipment as requested in the **Cross-Country Rallies and Bajas Appendices, Art. 081.23.**

01.58 PRODUCTION CATEGORY

Motorcycles in Production **category** are based on road legal, series production motorcycles.

All motorcycles will be according to Group A1 (Art. 01.07) and certified by the FIM.

A manufacturer must have built a minimum of 200 units before the date of the FIM certification.

Motorcycles, eligible for certification by the FIM, shall be standard catalogue production models which shall have been manufactured within the preceding 5 years, sold for everyday road use and completely equipped with full lighting equipment.

Note also Art. 01.59 – Certification **Requirements**

58.01 Class

Motorcycles in the Production category are divided into 2 classes:

Production 450cc:

Single and twin cylinder engines up to 450cc

Production over 450cc:

Single and twin cylinder engines over 450cc and up to 700cc

58.02 Machine specifications

All motorcycles must comply in every respect with all the requirements for Enduro in this Appendix, including Diagramme "S". In case of conflict, this discipline specification has priority.

All motorcycles of this type must be in Category 1, Group A1.

58.03 Pieces which cannot be changed

Motorcycles in the Production **category** shall compete without any change of the **marked** intrinsic parts during the event, as a test of endurance and reliability of the production model.

These **marked** intrinsic parts are:

- The frame
- The engine as a complete unit, i.e. crankcase(s), cylinder(s), cylinder head(s) and the carburation instrument(s)
- The front fork suspension assembly and fork clamps
- The swing-arm

These intrinsic parts shall be marked at the initial technical inspection. These parts may not be replaced during the entire event.

Note: Any change of the intrinsic parts during the event will entail a change of **category** (from Production **category** into **Superproduction category**) and in a time penalty (see Sporting Regulations Cross Country Rallies/Baja).

Beside normal maintenance service during an event, other interventions allowed to the motorcycle when required are: repairs of unmarked damaged parts by wear or as a result of an accident. In this last case, the rider must inform the Technical Steward.

58.04 Modifications from the motorcycles authorised

Modifications to the original certified motorcycle are only authorised as described below:

58.04.1 Carburation instrument(s)

The certified carburation instrument(s) and size (diameter) must remain as original. Settings may be modified.

58.04.2 Engine

No modifications are allowed to the engine crankcases, cylinder(s) and cylinder head.

Porting and polishing of the cylinder head(s) normally associated with individual tuning such as gas flowing, including the combustion chamber is allowed.

The crankshaft, connecting rod(s) and piston(s) may be modified. Bore and stroke must remain as original.

The compression ratio may be modified.

The gearbox casings must remain as original. Gearbox internal parts may be modified.

The clutch type (wet or dry, operated by hydraulics or cable) must remain as original.

The generator and ignition system may be modified or replaced.

The original water radiator/oil cooler may be modified or replaced. An additional radiator may be fitted, without changing the profile of the motorcycle.

The engine number must remain visible at all times.

58.04.3 Exhaust system

The exhaust system may be modified or replaced. The silencer(s) must be on the same side(s) of the homologated model.

The exposed edge(s) of the exhaust pipe(s) outlet(s) must be rounded to avoid any sharp edges.

58.04.4 Frame and ancillaries

The main frame and sub-frame assembly may only be modified by the addition of gussets and brackets.

The main frame must be marked with the original Vehicle Identification Number (VIN). The frame number (VIN) must remain visible at all times.

The frame must not be replaced during the event. The frame may be repaired under the supervision of the Technical Steward.

The air cleaner compartment (air-box) may be modified or replaced. The air cleaner element may be replaced.

Foot controls may be modified or replaced, but their original mounting points must be used.

Chain and sprocket size and dimensions may be modified.

58.04.5 Handlebars and instrument panel

Handlebars can be modified or changed, but the mounting points must remain as original.

Hand controls (throttle grip, clutch and brake levers) may be modified or replaced.

Instruments (speedometer, tachometer, etc), navigation instruments, electronic devices, electric cables, connectors, battery and switches **may be modified, added or replaced.**

The additional navigation instruments may change the side profile.

58.04.6 Streamlining

The type of fairing (either mounted on the frame or on the front fork) may be changed. The height of the fairing may be modified in order to protect the navigation instruments and instrument panel.

58.04.7 Suspensions

The front fork assembly **can be modified/replaced but the external diameter of the tubes** must remain original. Triple clamps (top and bottom) must remain as original. The internal settings of the front fork, oil seals, valves, springs **and spacers** may be modified or replaced.

A steering damper may be modified, replaced or added.

The rear suspension unit(s) and spring may be modified or replaced.

The rear swing-arms must remain as certified. The rear suspension linkage may be modified or replaced, but their pivot points must remain as on the original homologated model.

58.04.8 Brakes, wheels and rims

The front and rear discs may be replaced, but the diameter must remain as original. Brake lines and brake pads may be modified or replaced.

Wheel rims, hubs and spokes may be modified or replaced.

58.04.9 Mudguards

Front and rear mudguards may be modified or replaced. Their original mounting points **and location** must be used.

58.04.10 Fuel tank(s)

Fuel tanks may be replaced but the appearance (in profile) must remain as the original model.

Additional fuel tanks are permitted to be mounted on either side of the motorcycle. The(ir) position is limited between the fuel tank and not further than a vertical line drawn through the rear wheel axle (see also Art.58.02.4).

The **total** fuel capacity carried in all tanks **is 35 litres maximum**.

58.04.11 Seat

The seat may be modified or replaced.

58.04.12 Other items which may be modified or replaced from those fitted to the certified motorcycle

Any type of lubrication, brake or suspension fluid may be used.

Any type of spark plug and plug cap may be used.

Any inner tube (if fitted) or inflation valves may be used.

Wheel balance weights may be discarded, changed or added to.

Gaskets and gasket material.

Bearings (ball, roller, tapered, plain, etc.) of any type or brand may be used.

Fasteners (nuts, bolts, screws, etc.).

External surface finishes and decals.

58.04.13 Weight

Unrestricted.

01.59 CERTIFICATION REQUIREMENTS

Motorcycles in Production **category** must be certified by the FIM.

Each **manufacturer** or his legal representative may request certification **by sending to the FIM** documents and **road traffic certificates** which are in conformity with **Art. 01.58**.

Certification **criteria are** defined by **the** CTI.

Each manufacturer or his legal representative must provide the following characteristics and identifications:

- Motorcycle/ model - year
- VIN (Vehicle Identification Number per road legal model)
- Drawing of motorcycle in profile (L + R), including the exhaust system
- Frame drawing + main dimensions
- Crankcases + main dimensions
- Cylinder
- Cylinder head
- Clutch type (wet or dry, manual or hydraulic)
- Carburation instruments (type and dimensions)
- Front fork
- Swingarm

The CTI Panel and **the** CER Commission will meet once a year **to approve** the certifications.

The classification in categories Production 450cc and Production over 450cc is valid only when all certification documents have been presented by the manufacturer or his legal representative to the FIM.

01.60 SUPERPRODUCTION CATEGORY

Motorcycles in **Superproduction category** are based on a road legal single unit/ prototype according to Group A1 or C (Art. 01.07) and do not require to be certified by the FIM.

Motorcycles may be manufactured on a "one-off" basis, but must comply in all respects to the 1968 Vienna Convention, even if the country in which the machine was manufactured is not a signatory of that Convention, and be registered for road use.

Motorcycles of this type may be in:

Category I	Group A1
Category I	Group B1 – Sidecars
Category I	Group B2 – Sidecars
Category II	Group C – 2-wheel driven Motorcycles

60.01 Class

Motorcycles in the Superproduction category are divided into 2 classes:

Superproduction 450cc:

Single and twin cylinder engines up to 450cc

Superproduction over 450cc:

Single and twin cylinder engines over 450cc and up to 1300cc

60.02 Limitation of the main parts

Per rider, only one (1) frame, one (1) engine and two (2) spare engines with identical specifications must be marked and sealed by the Technical Stewards at the initial technical inspection, for use during the entire duration of the event.

60.03 Exhaust system

The exposed edge(s) of the exhaust pipe(s) outlet(s) must be rounded to avoid any sharp edges.

60.04 Frame and ancillaries

The frame must not be replaced during the event. The frame may be repaired under the supervision of the Technical Steward.

60.05 Fuel tank(s)

The total fuel capacity carried in all tanks is 35 litres maximum.

60.06 Weight

Unrestricted.

01.61 QUAD CATEGORY

The machines in Quad category are based on road legal, series production quads according to Group G or H and do not require to be certified by FIM.

– Group G/ Quad Racers:
Propelled by the action of two wheels (2 wheel driven).

– Group H/ Quad Racers:
Propelled by the action of four wheels (4 wheel driven)

Refer to Article 01.7/ Classes for definition.

61.01 Class

There is no restriction placed on the make, construction of type of **quad**, other than specified below. The cylinder capacities must be:

Group G:

- from 250cc up to 350cc for two cylinder, 2-stroke engines
- up to 500cc for single cylinder, 2-stroke engines
- up to 750cc for single or twin cylinders, 4-stroke engines.

Group H:

- up to 900cc for single or twin cylinders, 4-stroke engines

61.02 Machine specifications

The **machine** is steered by the front wheels only.

61.03 Limitation of the main parts

Per rider, only one (1) frame must be marked and sealed by the Technical Stewards at the initial technical inspection, for use during the entire duration of the event.

The number of engines is free.

61.04 Engine

The engine number must remain visible at all times.

61.05 Exhaust system

The silencer must not go beyond the rear extremities of the quad. The exhaust pipe of the silencer must be protected by a rounded edge of minimum 4 mm.

61.06 Frame and ancillaries

The main frame must be marked with the original Vehicle Identification Number (VIN). The frame number (VIN) must remain visible at all times.

The frame must not be replaced during the event. The frame may be repaired under the supervision of the Technical Steward.

61.07 Handlebars

The width of the handlebars is not less than 600mm and not more than 850mm.

The handlebars must be equipped with a protection pad on the cross bar. Handlebars without a cross bar must be equipped with a protection pad located in the middle of the handlebars, covering widely the handlebars clamps.

Exposed handlebar ends must be plugged with a solid material or covered with rubber.

Stops, (other than steering dampers) must be fitted to ensure a minimum clearance of 30mm between the handlebars with levers and the tank when on full lock to prevent the rider from trapping his fingers.

Handlebar clamps must be very carefully radiused and engineered so as to avoid fracture points in the bar.

If hand protectors are used they must be of a shatter-resistant material and have a permanent opening for the hand.

61.08 Control levers

All handlebar levers (clutch, brake, etc.) must be in principle ball ended (diameter of this ball to be at least 16 mm). This ball can also be flattened, but in any case the edges must be rounded (minimum thickness of this flattened part 14 mm). These ends must be permanently fixed and form an integral part of the lever.

Each control lever (hand and foot levers) must be mounted on an independent pivot.

61.09 Throttle controls

Throttle controls must be self closing when not held by the hand.

Quads must be equipped with a **safety** ignition cut out switch, which must stop the primary circuit and **must be permanently attached** to the rider by a non-elastic, spiral cable of adequate length (max. **100cm straightened**), similar to a telephone cable.

61.10 Number plates

Four number plates are required:

- 1 plate fixed to the front of the machine at the level of the head lamp, facing forward.
- 1 plate on each side of the machine placed on the rear mudguard.
- 1 plate attached to the rear bumper.

The number plates must have a **red** background with **white** numbers. They must be placed centrally and as vertically as possible. See Article 01.55 for dimensions.

The rider must display his starting number on his jersey or bib.

61.11 Suspensions

All the mountings of the front and rear suspension units, suspension arms and the steering spindle are retained by a safety wire or a splitpen.

61.12 Brakes, wheels and rims

The rear wheel rim diameter cannot exceed 12 inches in Group G and **15 inches in Group H**. Wire spokes are not authorised.

Every front wheel must have a single, functional brake installed on each axle and be operated by a handlebar mounted lever.

At the rear, the vehicle must have a brake on each wheel or a brake installed jointly on the rear wheel axle, operated either by a lever on the handlebar or by a foot pedal.

61.13 Mudguards

The front and rear wheels must be covered by mudguards made of flexible materials, covering each wheel over an area of minimum 30 degrees.

61.14 Tyres

Tyres with metal studs, spikes, chains or any other anti-skid devices are not permitted.

Scoop or paddle tyres (continuous radial rib) are forbidden.

61.15 Fuel tank(s)

Extra fuel tanks must be at least 25 mm (1 inch) away in relation to the edges of the protective barrier.

61.16 Protection (see Diagramme Q)

The secondary chain transmission must be equipped with a cover/shield protecting both the chain sprocket and the brake disc.

A countershaft sprocket guard is compulsory. This cover/shield must cover the sprocket by 30 % minimum and prevent the rider's hand/foot becoming trapped. The complete length of the lower chain run must be shielded by a guard or a protection tube, securely fixed.

A crash 'bar' or 'guard' must be fixed at the front and the rear of the vehicle.

A protective barrier (or 'guard') of a round profile (minimum diameter: 25 mm or 1 inch) must be installed on each side of the vehicle. This protective barrier must be fitted in such a way that it is in alignment with the wheels to eliminate entanglement. There shall be no prominent (sharp) parts.

A structure of crossed belts or a metallic grid must be fitted to fill the opening between the wheels and the barrier, to prevent the riders' foot from accidentally touching the ground.

61.17 Dimensions

The width cannot exceed 1300mm **for group G and 1400mm for group H.**

The maximum height at the rider's seat level is 950mm **for group G and 1000mm for group H.**

61.18 Weight

Unrestricted.

01.63 FUEL, OIL AND COOLANTS

All motorcycles must be fuelled with unleaded petrol, as this term is generally understood.

For the main article, refer to the same number in the General section.

01.65 EQUIPMENT AND PROTECTIVE CLOTHING **Clothing and footwear**

During practising and competition, the riders and passengers must wear the following clothing and footwear:

65.01

Riders must wear protective clothing of cloth or leather. Knee-length boots, and gloves of leather or an equivalent material must be worn.

A chest-protector and/or with additional back protection is recommended.

65.05

The fabric or substance of all clothing and its lining must be tested and certified by an official scientific institute, taking into account the fire and wear resistant qualities of all parts of the clothing which come into direct contact with the skin. It must be anti-flammable and may be approved by an FMN (National Motorcycling Federation).

For the main article, refer to the same number in the General section.

01.67 WEARING OF HELMETS

For the main article, refer to the same number in the General section.

01.69 HELMET OPERATIVE INSTRUCTIONS

For the main article, refer to the same number in the General section.

01.70 RECOGNISED INTERNATIONAL HELMET APPROVAL MARKS

- Europe 22-05, 'P', 'NP' ou 'J'
- Japan JIS T 8133 : 2000
- USA SNELL M 2005

(see International Helmet Standards in diagram section)

01.71 EYE PROTECTION

For the main article, refer to the same number in the General section.

01.73 NATIONAL COLOURS FOR HELMETS

For the main article, refer to the same number in the General section.

01.75 BADGE OF THE FIM

For the main article, refer to the same number in the General section.

01.76 NUMBER SASHES (BIBS)

Starting numbers must be conform to the following:

76.01

Black numbers on a white background must be used.

76.02

The size of the area in which numbers are printed is: 25 x 25 cm maximum.

76.03

Height of number: 15 cm

76.04

Width of number: 6 cm

76.05

Width of stroke: 2 cm

76.06

Only the space outside the 25 x 25 cm area may be used for publicity.

76.07

Bibs manufactured from PLASTIC material are not allowed.

01.77 CONTROL

77.01 Verification

General

A rider is at all times responsible for his machine.

For the main article, refer to the same number in the General section.

77.02.1 The technical control must be carried out as follows:

ISDE: 2 days before the start on the first day

World Championship and other 2 Days' Enduro events: 1 day before the start.

77.02.2 The technical control must be carried out in conformity with the times fixed in the Supplementary Regulations of the event.

77.02.3 The rider must personally present a clean motorcycle, the prescribed helmet and the technical card duly filled in and confirmed.

77.02.4 The rider may only present one motorcycle.

77.02.5 The sound control must be carried out first. The exhaust silencer must be marked with paint. The sound level must be recorded in the technical card.

77.02.7 An overall inspection of the motorcycle must be carried out in conformity with the FIM rules. Accepted motorcycles will be marked in conformity with Arts. 061.44 or 062.23 of the Enduro Sporting Rules.

77.02.8 Riders must confirm their agreement by signing the register. The machine will then be placed in a closed park.

77.02.9 Immediately after technical control the Chief Technical Steward must submit to the Clerk of the Course the list of accepted riders, accepted machines, and sound figures.

77.02.10 During the event, in the arrival and departure areas, the technical steward must control the repairs and changes made to the machines. He must control that no outside assistance is made. He must also control the condition of the machines.

77.02.11 At individual time checks, the technical steward must control repairs and other technical assistance. He must also control that the machines are marked (seal on frame) in order to ensure that no change in motorcycle occurred on the course.

77.02.12 At the arrival, at the end of each day, the technical steward must check all parts and the condition of the machine. A rider is allowed an extra 30 minutes to repair or replace a silencer only (see Arts. 061.44.5 and 062.23.2).

Competitors must retrieve their machines within 30 minutes after the opening of the closed park area, except for the machines which are chosen for disassembly. After this time limit, the closed park officials will no longer be responsible for the machines left behind.

77.02.13 At the arrival, at the end of the competition, all the marked parts on the motorcycles must be controlled. After control, the machines must be placed in a closed park for 30 minutes in case of a protest or shall further examination be required.

77.02.14 If a motorcycle or a part of a motorcycle must be verified and completely dismantled, the motorcycle, the part or the group of parts must be sealed and shipped to a place where the required tools are present for a disassembly. The Jury must take the decision for this operation.

77.02.15 The disassembly and the verification of the motorcycle or the parts in question must be with the presence of the Technical Steward, appointed to the event.

77.02.16 The Organiser will pay the costs for the transportation and for the verification according to Articles 77.02.14 and 77.02.15.

77.02.17 If a disassembly is required and ordered by the Jury, following a protest, according to Art. 77.02.14 and 77.02.15, the losing party will incur all the transportation and verification costs, or a part of these costs fixed by the Jury.

77.05 Dangerous machines

For the main article, refer to the same number in the General section.

01.79 SOUND CONTROL

Sound will be controlled to limits as mentioned in Art. 79.11.

For the main article, refer to the same number in the General section.

79.05

The RPM depends upon the mean piston speed corresponding to the stroke of the engine (See table). The RPM will be given by the following formula:

$$N = \frac{30,000 \times cm}{l}$$

in which N = prescribed RPM of engine
cm = fixed mean piston speed in m/s
l = stroke in mm

Stroke in mm	R P M (13 m/s)	Stroke in mm	R P M (13 m/s)
30	13,000	66	5,909
31	12,580	67	5,820
32	12,187	68	5,735
33	11,818	69	5,652
34	11,470	70	5,571
35	11,147	71	5,492
36	10,833	72	5,416
37	10,540	73	5,342
38	10,263	74	5,270
39	10,000	75	5,200
40	9,750	76	5,131
41	9,512	77	5,064
42	9,285	78	5,000
43	9,069	79	4,936
44	8,863	80	4,875
45	8,666	81	4,814
46	8,478	82	4,756
47	8,297	83	4,698
48	8,125	84	4,642
49	7,959	85	4,588
50	7,800	86	4,534
51	7,647	87	4,482
52	7,500	88	4,431
53	7,358	89	4,382
54	7,222	90	4,333
55	7,090	91	4,285
56	6,964	92	4,239
57	6,842	93	4,193
58	6,724	94	4,148
59	6,610	95	4,105
60	6,500	96	4,062
61	6,393	97	4,020
62	6,290	98	3,979
63	6,190	99	3,939
64	6,093	100	3,900
65	6,000	101	3,861

79.07

The sound level for engines with more than one cylinder will be measured on each exhaust end.

79.17 Sound control during the competition

In a competition which requires sound control tests during the event, machines must comply with the sound limits, except taking into account the tolerance as per Art. 79.15.

01.80 GUIDELINES FOR USE OF SOUND LEVEL METERS

For the main article, refer to the same number in the General section.

01.81 TIMEKEEPING

Since 01.01.1993, the responsibility for Timekeeping has been referred to the Sporting Commission.

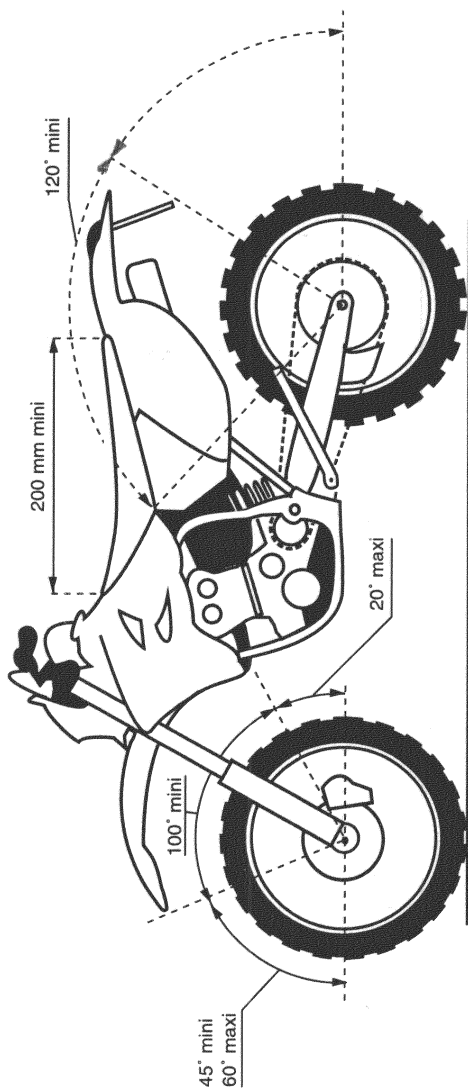

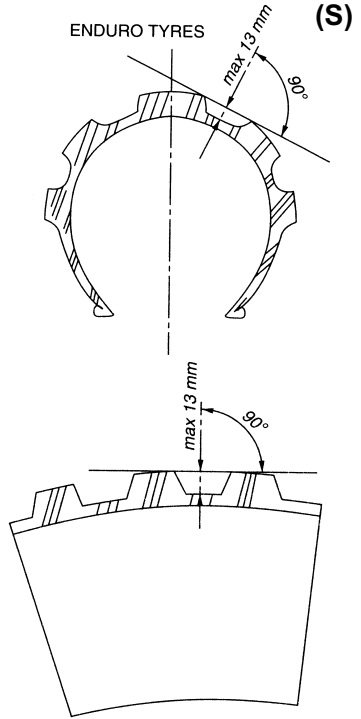
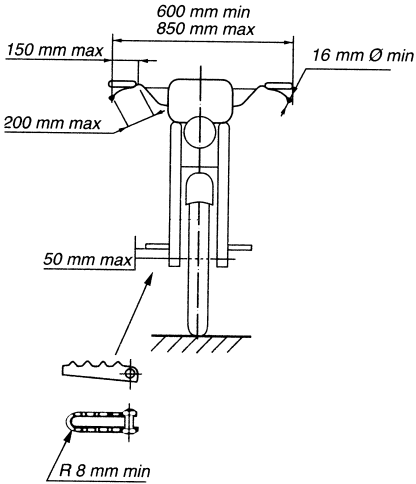

Art. 51.06
Example:
Studs/Clous

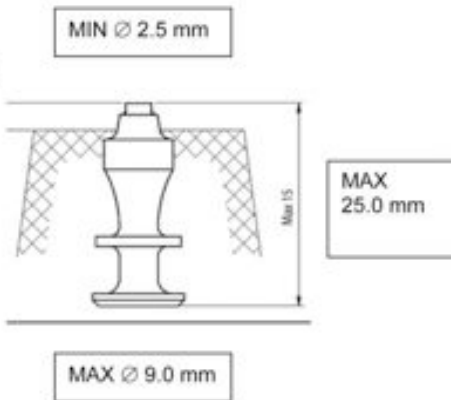

CER

ENDURO / SIDECAR

N



DIAGRAMME Q QUAD RACER



Max. 1300 mm. Group G
1400 mm. Group H

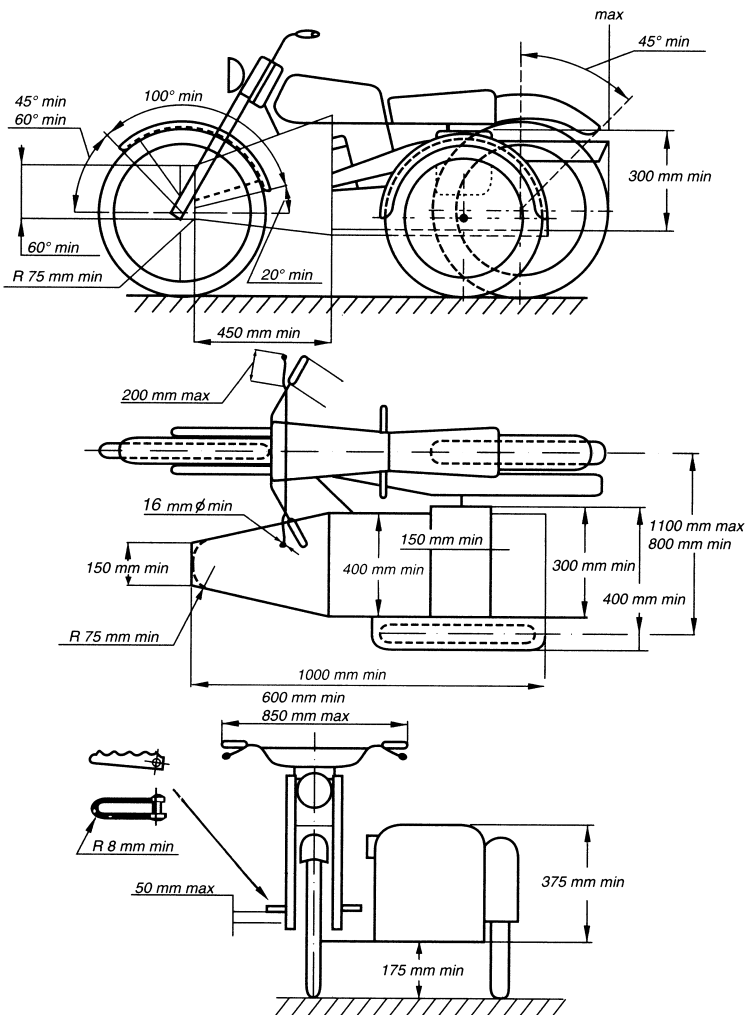
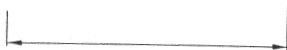
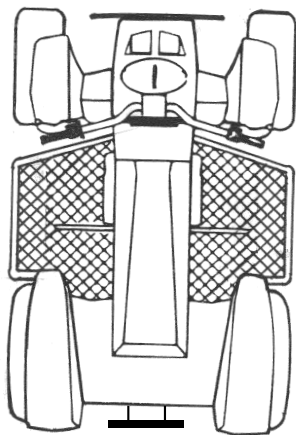
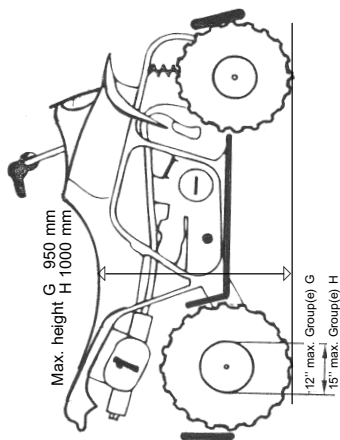
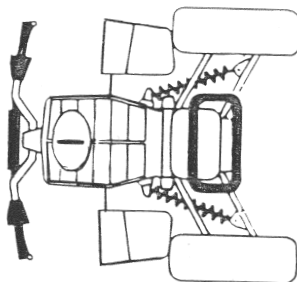

Max. height G 950 mm
H 1000 mm

12" max. Group(e) G

15" max. Group(e) H

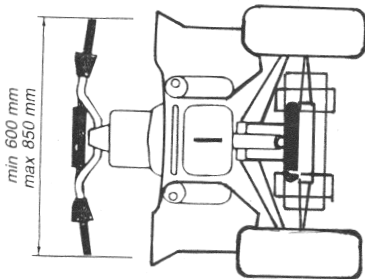

min 600 mm
max 850 mm

DIAGRAMME Q (suite)

PROTECTIVE DEVICES (REAR) : sprocket and disc
SYSTEMES DE PROTECTION (AR): couronne et disque

- (1) Chain guard, mounting to a height corresponding to minimum 90°
Sabot inférieur remontant à la hauteur correspondant à 90° minimum

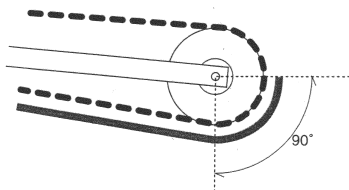

- (2) Chain guard + (3) protective guard
Sabot inférieur + (3) barre de protection

